

TECHNICAL CATALOGUE

GAS BALL VALVES:
LONDON®





ITAP SpA, founded in Lumezzane (Brescia) in 1972, is currently one of the leading production companies in Italy of valves, fittings and distribution manifolds for plumbing and heating systems. Thanks to fully automated production processes, with 72 tooling machines and 51 assembly lines, we are able to produce 200,000 pieces per day. Our innate pursuit for innovation and observance of technical regulations is supported by the company certification ISO 9001: 2008. The company has always considered its focus on quality as the main tool to obtain significant business results: today ITAP SpA is proud to offer products bearing the approval of numerous international certifying bodies.





FULL FLOW GAS
BALL VALVES:
LONDON®

EN 331 APPROVED.

GAS BALL VALVES

066

LONDON®
BALL VALVE,
FULL FLOW



SIZE	PRESSURE	CODE	PACKING
1/4" (DN 8)	5bar/72,5psi	066B014	12/192
3/8" (DN 10)	5bar/72,5psi	066B038	12/192
1/2" (DN 15)	5bar/72,5psi	066B012	10/100
3/4" (DN 20)	5bar/72,5psi	066B034	8/64
1" (DN 25)	5bar/72,5psi	066B100	6/48
1"1/4 (DN 32)	5bar/72,5psi	066B114	4/32
1"1/2 (DN 40)	5bar/72,5psi	066B112	2/16
2" (DN 50)	5bar/72,5psi	066B200	2/14

TECHNICAL SPECIFICATIONS

EN 331 APPROVED.

Female/female threads.

Body in nickel-plated brass.

Lever handle in steel.

Minimum and maximum working temperatures: -20°C, 60°C.

Female thread ISO 7/1 Rp parallel

(equivalent to DIN EN 10226-1 and BS EN 10226-1).

MATERIALS

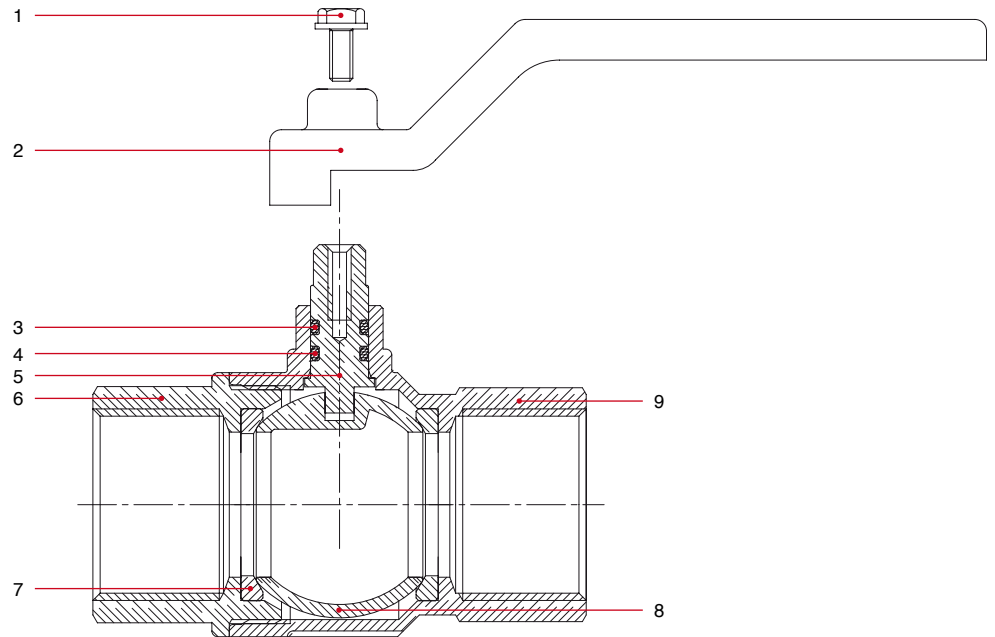

POS.	DESCRIPTION	N.	MATERIAL
1	Screw	1	Zinc-plated steel Fe CB4
2	Lever handle	1	Zinc-plated and varnished steel Fe.P04
3	O-Ring	1	VITON®
4	O-Ring	1	NBR
5	Stem	1	Brass CW614N
6	End adapter	1	Nickel-plated brass CW617N
7	Seat	2	P.T.F.E.
8	Ball	1	Chrome-plated brass CW617N
9	Body	1	Nickel-plated brass CW617N



OVERALL DIMENSIONS

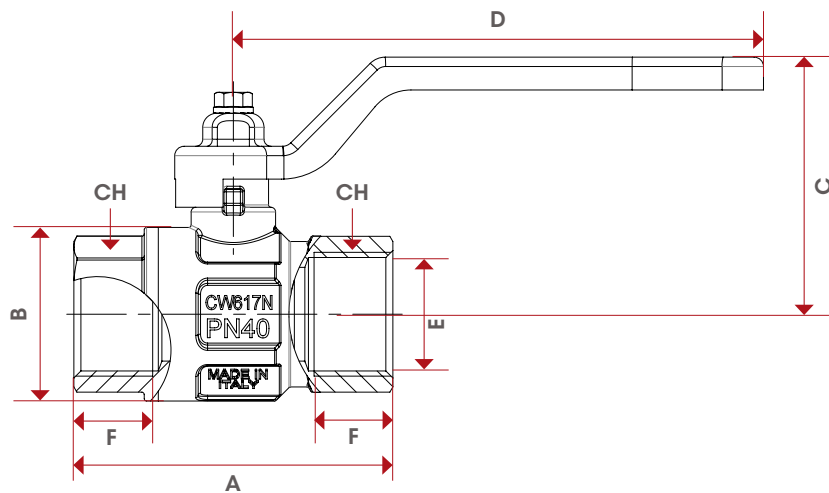

	1/4"	3/8"	1/2"	3/4"	1"	1"1/4	1"1/2	2"
DN	8	10	15	20	25	32	40	50
A	49,5	52,4	61	68	85	99,5	109	130
B	23,5	24	30,5	37	45,5	58	71	85
C	37,3	37,3	48,8	54,8	56,8	75	90,3	97,3
D	80	80	88,5	113	113	138	157,8	157,8
E	10	10	15	20	25	32	40	50
F	11	11,4	15	16,3	19,1	21,4	21,4	25,7
CH	18	21	25	31	38	47	54	66
Kg/cm ² bar	5	5	5	5	5	5	5	5
LBS - psi	72,5	72,5	72,5	72,5	72,5	72,5	72,5	72,5

CERTIFICATIONS



067

LONDON®
BALL VALVE,
FULL FLOW



SIZE	PRESSURE	CODE	PACKING
1/4" (DN 8)	5bar/72,5psi	067B014	12/192
3/8" (DN 10)	5bar/72,5psi	067B038	12/132
1/2" (DN 15)	5bar/72,5psi	067B012	10/100
3/4" (DN 20)	5bar/72,5psi	067B034	8/64
1" (DN 25)	5bar/72,5psi	067B100	6/48
1"1/4 (DN 32)	5bar/72,5psi	067B114	4/24
1"1/2 (DN 40)	5bar/72,5psi	067B112	2/16
2" (DN 50)	5bar/72,5psi	067B200	2/14

TECHNICAL SPECIFICATIONS

EN 331 APPROVED.

Male/female threads.

Body in nickel-plated brass.

Lever handle in steel.

Minimum and maximum working temperatures: -20°C, 60°C.

Female thread ISO 7/1 Rp parallel

(equivalent to DIN EN 10226-1 and BS EN 10226-1).

Male thread ISO 7/1 R taper

(equivalent to DIN EN 10226-1 and BS EN 10226-1).

MATERIALS

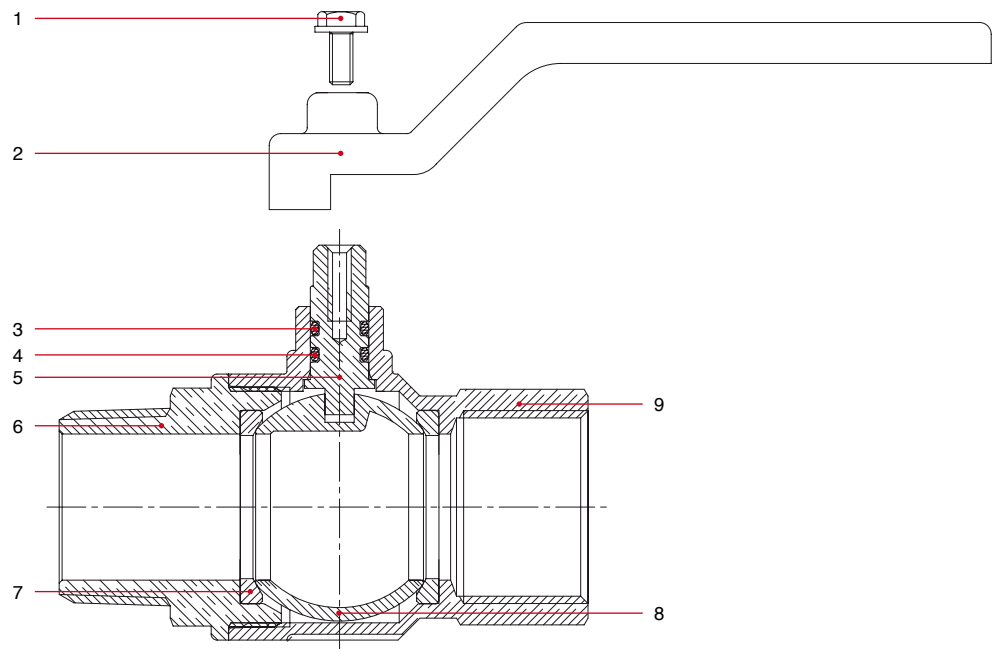

POS.	DESCRIPTION	N.	MATERIAL
1	Screw	1	Zinc-plated steel Fe CB4
2	Lever handle	1	Zinc-plated and varnished steel Fe.P04
3	O-Ring	1	VITON®
4	O-Ring	1	NBR
5	Stem	1	Brass CW614N
6	End adapter	1	Nickel-plated brass CW617N
7	Seat	2	P.T.F.E.
8	Ball	1	Chrome-plated brass CW617N
9	Body	1	Nickel-plated brass CW617N



OVERALL DIMENSIONS

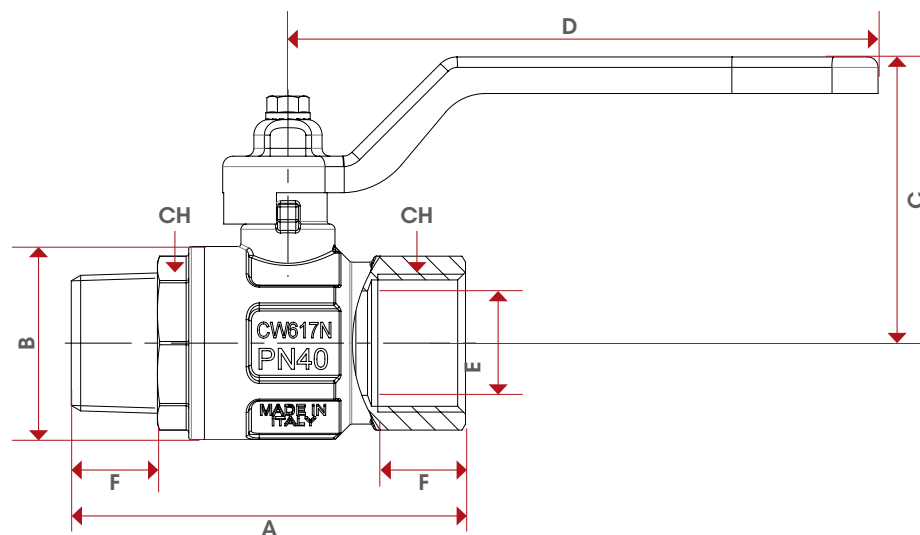

	1/4"	3/8"	1/2"	3/4"	1"	1 1/4"	1 1/2"	2"
DN	8	10	15	20	25	32	40	50
A	56,9	58,9	68	75,5	90,5	105	115,5	135,5
B	23,5	24	30,5	37	45,5	58	71	85
C	37,3	37,3	48,8	54,8	56,8	75	90,3	97,3
D	80	80	88,5	113	113	138	157,8	157,8
E	8	10	15	20	25	32	39	50
F	11	11,4	15	16,3	19,1	21,4	21,4	25,7
CH	18	21	25	31	38	47	54	66
Kg/cm ² bar	5	5	5	5	5	5	5	5
LBS - psi	72,5	72,5	72,5	72,5	72,5	72,5	72,5	72,5

CERTIFICATIONS



068

LONDON®
BALL VALVE,
FULL FLOW



SIZE	PRESSURE	CODE	PACKING
1/4" (DN 8)	5bar/72,5psi	068B014	15/165
3/8" (DN 10)	5bar/72,5psi	068B038	15/165
1/2" (DN 15)	5bar/72,5psi	068B012	10/110
3/4" (DN 20)	5bar/72,5psi	068B034	8/64
1" (DN 25)	5bar/72,5psi	068B100	6/48

TECHNICAL SPECIFICATIONS

EN 331 APPROVED.

Female/female threads.

Body in nickel-plated brass.

T handle in aluminium.

Minimum and maximum working temperatures: -20°C, 60°C.

Female thread ISO 7/1 Rp parallel

(equivalent to DIN EN 10226-1 and BS EN 10226-1).

MATERIALS

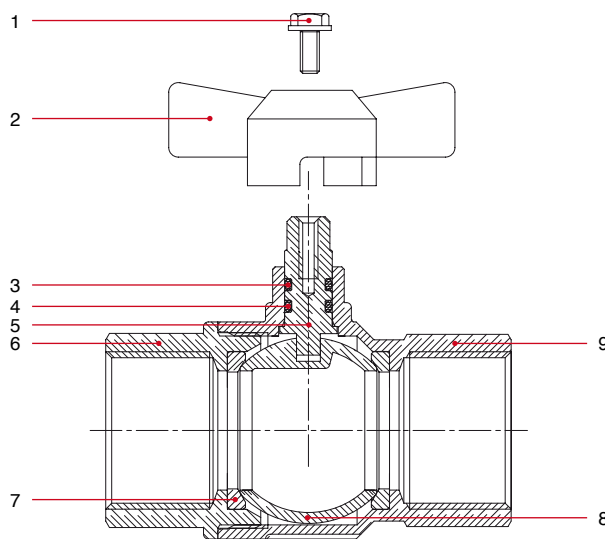

POS.	DESCRIPTION	N.	MATERIAL
1	Screw	1	Zinc-plated steel Fe CB4
2	T handle	1	Varnished aluminium
3	O-Ring	1	VITON®
4	O-Ring	1	NBR
5	Stem	1	Brass CW614N
6	End adapter	1	Nickel-plated brass CW617N
7	Seat	2	P.T.F.E.
8	Ball	1	Chrome-plated brass CW617N
9	Body	1	Nickel-plated brass CW617N



OVERALL DIMENSIONS

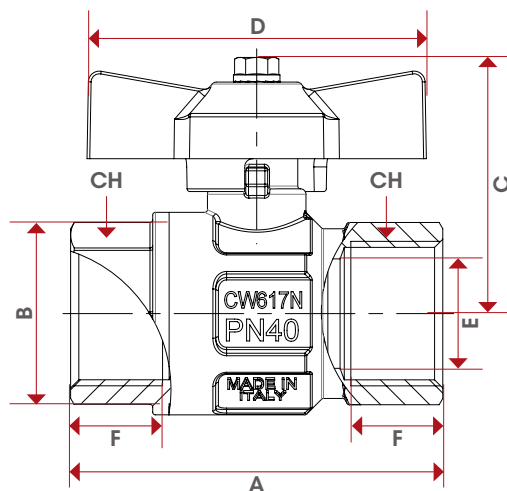

	1/4"	3/8"	1/2"	3/4"	1"
DN	8	10	15	20	25
A	49,5	52,4	61	68	85
B	23,5	24	30,5	37	45,5
C	37,3	37,3	48,8	54,8	56,8
D	47	47	54	62	62
E	10	10	15	20	25
F	11	11,4	15	16,3	19,1
CH	18	21	25	31	38
Kg/cm ² bar	5	5	5	5	5
LBS - psi	72,5	72,5	72,5	72,5	72,5

CERTIFICATIONS



069

LONDON®
BALL VALVE,
FULL FLOW



SIZE	PRESSURE	CODE	PACKING
1/4" (DN 8)	5bar/72,5psi	069B014	15/165
3/8" (DN 10)	5bar/72,5psi	069B038	15/165
1/2" (DN 15)	5bar/72,5psi	069B012	10/130
3/4" (DN 20)	5bar/72,5psi	069B034	8/64
1" (DN 25)	5bar/72,5psi	069B100	6/48

TECHNICAL SPECIFICATIONS

EN 331 APPROVED.

Male/female threads.

Body in nickel-plated brass.

T handle in aluminium.

Minimum and maximum working temperatures: -20°C, 60°C.

Female thread ISO 7/1 Rp parallel
(equivalent to DIN EN 10226-1 and BS EN 10226-1).

Male thread ISO 7/1 R taper
(equivalent to DIN EN 10226-1 and BS EN 10226-1).

MATERIALS

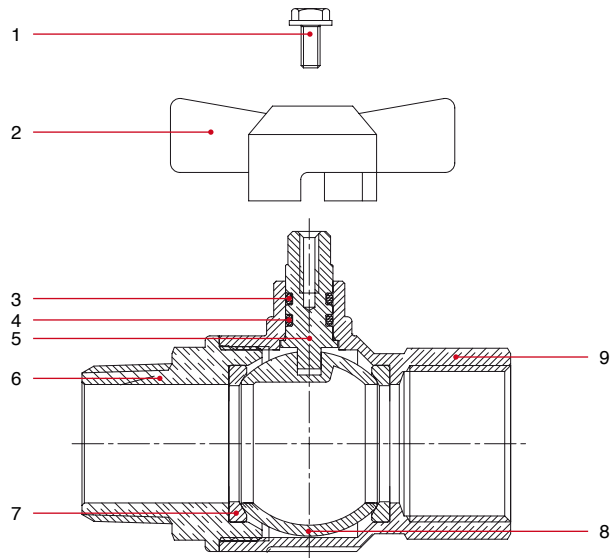

POS.	DESCRIPTION	N.	MATERIAL
1	Screw	1	Zinc-plated steel Fe CB4
2	T handle	1	Varnished aluminium
3	O-Ring	1	VITON®
4	O-Ring	1	NBR
5	Stem	1	Brass CW614N
6	End adapter	1	Nickel-plated brass CW617N
7	Seat	2	P.T.F.E.
8	Ball	1	Chrome-plated brass CW617N
9	Body	1	Nickel-plated brass CW617N



OVERALL DIMENSIONS

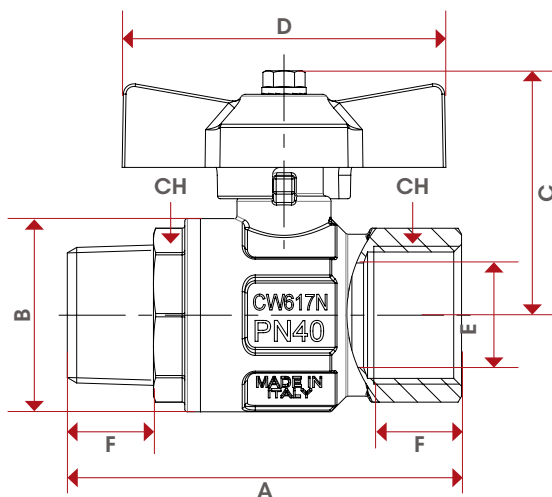

	1/4"	3/8"	1/2"	3/4"	1"
DN	8	10	15	20	25
A	56,9	58,9	68	75,5	90,5
B	23,5	24	30,5	37	45,5
C	37,3	37,3	48,8	46,8	50,8
D	47	47	54	62	62
E	8	10	15	20	25
F	11	11,4	15	16,3	19,1
CH	18	21	25	31	38
Kg/cm ² bar	5	5	5	5	5
LBS - psi	72,5	72,5	72,5	72,5	72,5

CERTIFICATIONS



266

LONDON®
BALL VALVE,
FULL FLOW



SIZE	PRESSURE	CODE	PACKING
1/4" (DN 8)	5bar/72,5psi	266B014	12/156
3/8" (DN 10)	5bar/72,5psi	266B038	12/156
1/2" (DN 15)	5bar/72,5psi	266B012	10/80
3/4" (DN 20)	5bar/72,5psi	266B034	8/64
1" (DN 25)	5bar/72,5psi	266B100	6/48
1"1/4 (DN 32)	5bar/72,5psi	266B114	4/24
1"1/2 (DN 40)	5bar/72,5psi	266B112	2/18
2" (DN 50)	5bar/72,5psi	266B200	2/14

TECHNICAL SPECIFICATIONS

EN 331 APPROVED.

Female/female threads.

Body in nickel-plated brass.

Flat lever handle in lined steel.

Minimum and maximum working temperatures: -20°C, 60°C.

Female thread ISO 7/1 Rp parallel

(equivalent to DIN EN 10226-1 and BS EN 10226-1).

MATERIALS

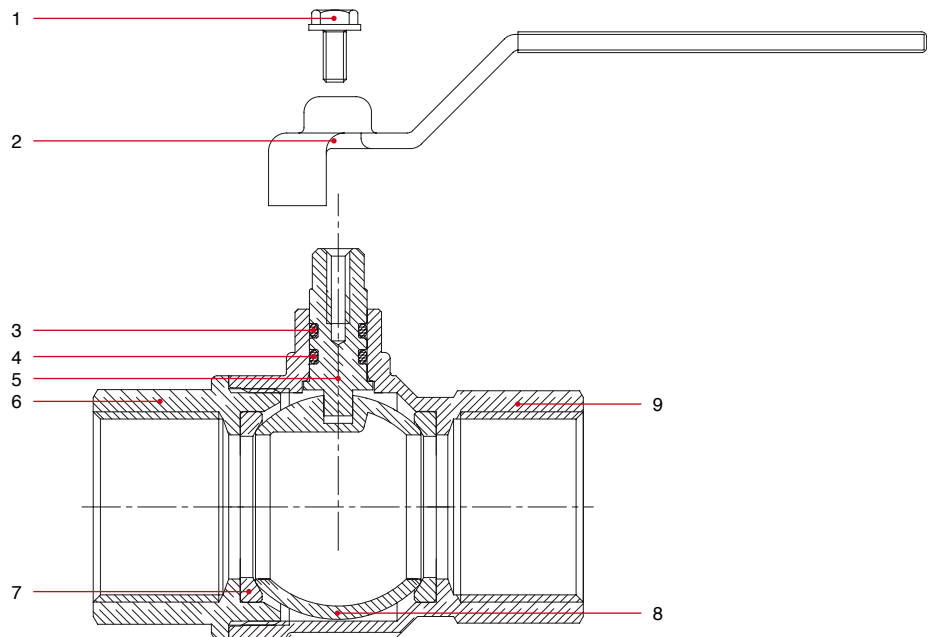

POS.	DESCRIPTION	N.	MATERIAL
1	Screw	1	Zinc-plated steel Fe CB4
2	Flat lever handle	1	Zinc-plated and plastic coated steel Fe.P04
3	O-Ring	1	VITON®
4	O-Ring	1	NBR
5	Stem	1	Brass CW614N
6	End adapter	1	Nickel-plated brass CW617N
7	Seat	2	P.T.F.E.
8	Ball	1	Chrome-plated brass CW617N
9	Body	1	Nickel-plated brass CW617N



OVERALL DIMENSIONS

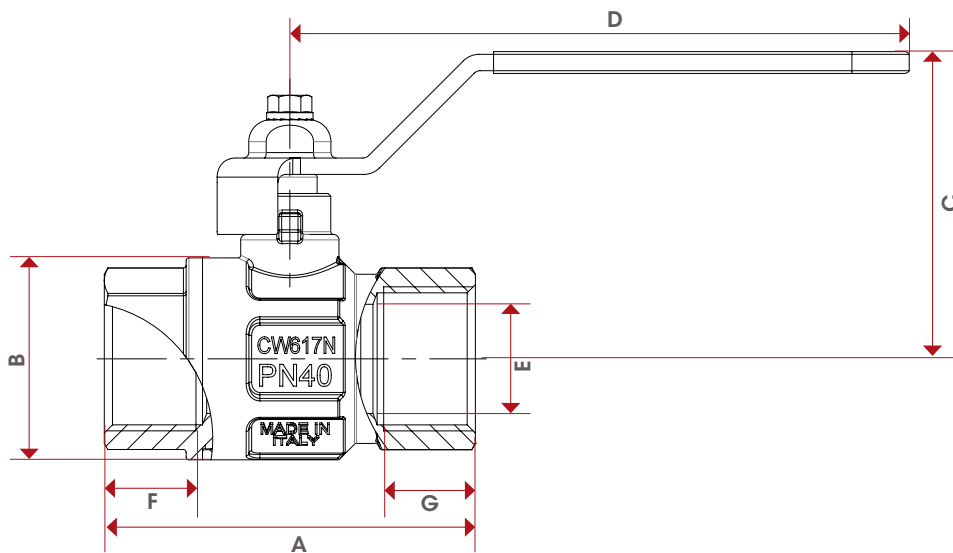

	1/4"	3/8"	1/2"	3/4"	1"	1 1/4"	1 1/2"	2"
DN	8	10	15	20	25	32	40	50
A	49,5	52,4	61	68	85	99,5	109	130
B	23,5	24	30,5	37	45,5	58	71	85
C	41,8	41,8	50,3	56,3	60,3	76,3	91,8	98,8
D	85,5	85,5	92,5	113,5	113,5	138	158	158
E	10	10	15	20	25	32	40	50
F	11	11,4	15	16,3	19,1	21,4	21,4	25,7
CH	18	21	25	31	38	47	54	66
Kg/cm ² bar	5	5	5	5	5	5	5	5
LBS - psi	72,5	72,5	72,5	72,5	72,5	72,5	72,5	72,5

CERTIFICATIONS



267

LONDON®
BALL VALVE,
FULL FLOW



SIZE	PRESSURE	CODE	PACKING
1/4" (DN 8)	5bar/72,5psi	267B014	12/156
3/8" (DN 10)	5bar/72,5psi	267B038	12/156
1/2" (DN 15)	5bar/72,5psi	267B012	10/80
3/4" (DN 20)	5bar/72,5psi	267B034	8/64
1" (DN 25)	5bar/72,5psi	267B100	6/48
1"1/4 (DN 32)	5bar/72,5psi	267B114	4/24
1"1/2 (DN 40)	5bar/72,5psi	267B112	2/18
2" (DN 50)	5bar/72,5psi	267B200	2/14

TECHNICAL SPECIFICATIONS

EN 331 APPROVED.

Male/female threads.

Body in nickel-plated brass.

Flat lever handle in lined steel.

Minimum and maximum working temperatures: -20°C, 60°C.

Female thread ISO 7/1 Rp parallel

(equivalent to DIN EN 10226-1 and BS EN 10226-1).

Male thread ISO 7/1 R taper

(equivalent to DIN EN 10226-1 and BS EN 10226-1).

MATERIALS

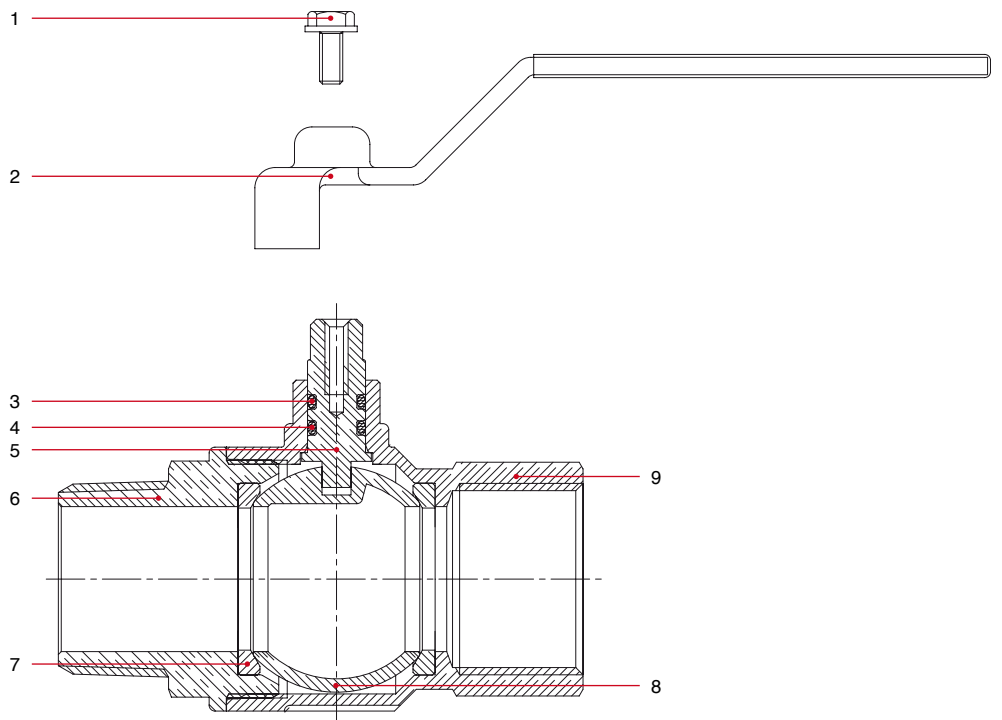

POS.	DESCRIPTION	N.	MATERIAL
1	Screw	1	Zinc-plated steel Fe CB4
2	Flat lever handle	1	Zinc-plated and plastic coated steel Fe.P04
3	O-Ring	1	VITON®
4	O-Ring	1	NBR
5	Stem	1	Brass CW614N
6	End adapter	1	Nickel-plated brass CW617N
7	Seat	2	P.T.F.E.
8	Ball	1	Chrome-plated brass CW617N
9	Body	1	Nickel-plated brass CW617N



OVERALL DIMENSIONS

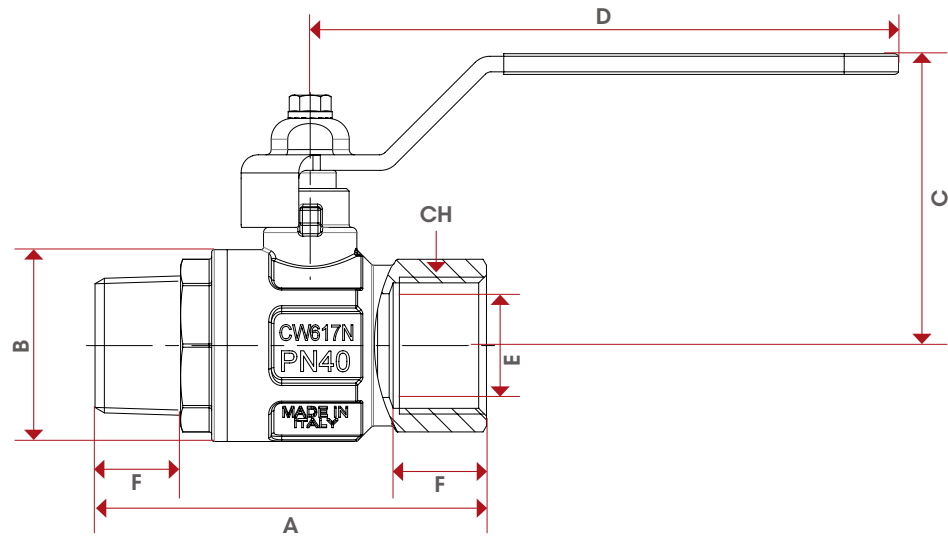

	1/4"	3/8"	1/2"	3/4"	1"	1 1/4"	1 1/2"	2"
DN	8	10	15	20	25	32	40	50
A	56,9	58,9	68	75,5	90,5	105	115,5	135,5
B	23,5	24	30,5	37	45,5	58	71	85
C	41,8	41,8	50,3	56,3	60,3	76,3	91,8	98,8
D	85,5	85,5	92,5	113,5	113,5	138	158	158
E	8	10	15	20	25	32	40	50
F	11	11,4	15	16,3	19,1	21,4	21,4	25,7
CH	18	21	25	31	38	47	54	66
Kg/cm ² bar	5	5	5	5	5	5	5	5
LBS - psi	72,5	72,5	72,5	72,5	72,5	72,5	72,5	72,5

CERTIFICATIONS



LOSS WITH WATER DIAGRAM

Art: 066 - 067 - 068 - 069 - 266 - 267

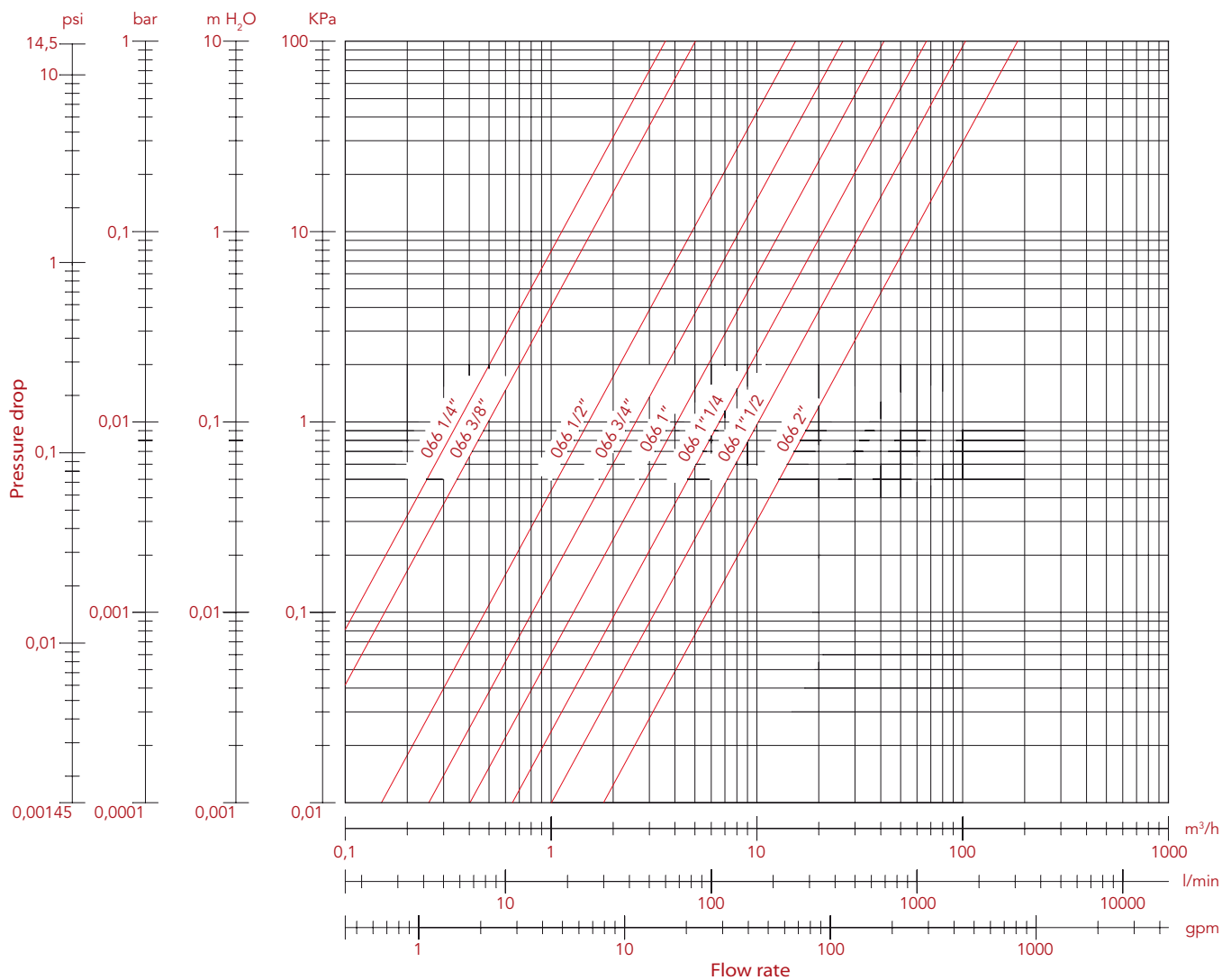

SIZE	1/4"	3/8"	1/2"	3/4"	1"	1 1/4"	1 1/2"	2"
Ø	10	10	15	20	25	32	40	50
Kv	3,45	5,00	15,65	26,26	41,44	63,69	101	169





PRESSURE-TEMPERATURE DIAGRAM

GAS BALL VALVES

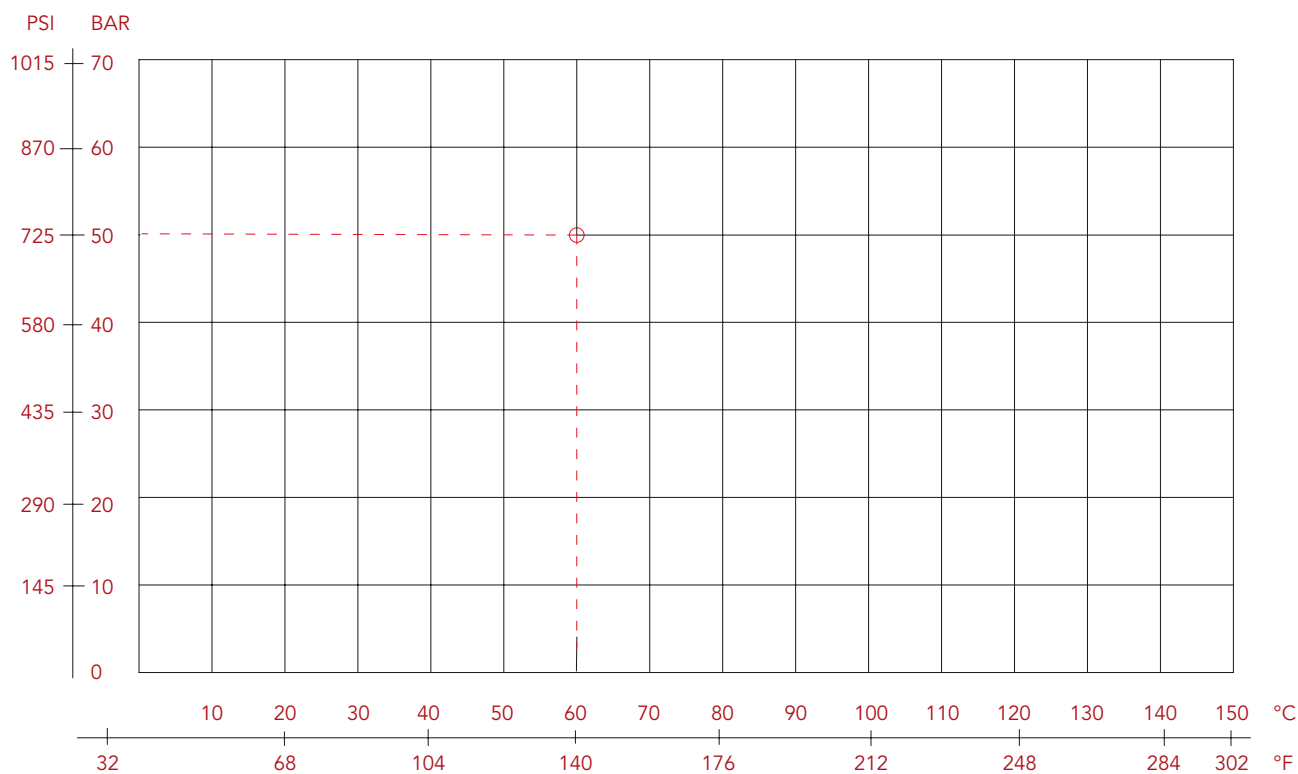

NB: Maximum working temperature for gas: +60 °C
The working pressure for gas is from 0 to 5 bar.

MANUFACTURER INSTRUCTIONS

Installation

The itap S.p.A.'s valves are bi-directional, that means they manage the flow in both the directions. The valves are composed by a ball, two seal in PTFE material, one stem, two sailing rings (O-Rings), one handle and a couple of parts made of brass (body and end adopter) that contain them and that are assembled by means of thread and a sealed material to obtain their aim. To avoid that the sealing material gets brake and than the valve gets lose the connection between body and the end adopter, it's necessary to avoid to submit the two parts under the influence of a torque.

For their installation ones have to use the normal hydraulic practices, and in particular:

- Ones have to be sure that the two pipes are correctly aligned,
- during the assembling ones have to apply the assembling tool at the end that is nearest to the pipe,
- the application of the sealing materials by the fitter (PTFE or hempen cloth) must be limited at the threat zone. An excess should interferes in the ball-gasket's closure zone, compromising the tightness.
- In the case that the fluid transported presents some impurities (dust, water too hard, etc.) ones have to remove these impurities by the means of a filter. Otherwise they could damage the seals.

Disassembly the installed valve

To remove the valve from the pipe line or anyhow before to unscrew the junctions linked to it:

- wear the clothing protective normally required to work with the fluid transported within the line.
- Depressurize the line and operate in this way:
 - positioning the valve in opened position and than empty the line
 - handle the valve to put down the residue pressure contained inside the space between the ball and the body before of remove it from the line,
 - during the disassembly apply the screw tool at the end of the valve nearest the pipe

Maintenance

Verify the valves periodically, in function oh their application's field and in function of their work conditions, to be sure that the valves work correctly.

Warnings

- any deterioration or destruction of any part of the manually operated ball valve shall result in the need to replace complete valve: alterations to any part of the complete valve shall result in the valve no longer being in compliance with the performance requirements of EN 331 standard;
- ensure that the manually operated ball valve allows an adequate flow rate for its intended use;
- all installations should be performed in accordance with existing local installation regulations and codes of practice where they exist;
- it is imperative to follow the installation instructions of the manually operated ball valve manufacturer and of the appliance manufacturer, including those for the correct position of the connection point for the valve.





TEC

LONDON[®]



FULL FLOW GAS BALL VALVES: LONDON®



NOTES

Horizontal dashed lines for notes.





ITAP S.p.A.
Via Ruca 19
25065 Lumezzane
Brescia (ITALIA)
Tel 030 89270
Fax 030 8921990
www.itap.it - info@itap.it